

PH: 407-855-2899

FAX: 407-855-2855



Mold Control Systems, Inc.

SITC-15 Temperature Controller
GITC-15 Temperature Controller
Mainframe



Operation Manual









Contents:

SITC Quick Reference:	Pg. 2	Display Codes:	Pg. 9
GITC Quick Reference:	Pg. 3	Mainframe Installation: ..	Pg. 10
Basic Operation Procedures:.	Pg. 4	Cable Pinout:	Pg. 13
SITC Parameters:	Pg. 7	MFCP Mainframe:	Pg. 14
GITC Parameters:	Pg. 8	1-3 Zone Mainframe	Pg. 15

SITC-15 Quick Reference

Change set-point temp -  or  to desired set-point temp.



Change mode - press  until flashing LED is under desired mode, then 

Change parameters - press  until desired parameter is found. Use  or  to adjust the parameter.  when finished.

Display Amps/Volts - press 



Set-Point Value Display



-  When decimal is lit, manual percentage power is engaged
-  When decimal is lit, voltage is displayed $\pm 3\%$
-  When decimal is lit, temp. is displayed in Celsius





Process Value Display

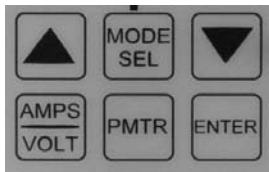

-  When decimal is lit, amperage is displayed
-  When decimal is lit, output power is on

User Input Keypad



-  Up/down keys
For adjustment of setpoint/parameters
-  Mode Select key
Manual, Auto, Standby, and Boost
-  Amps/Volt key
View Current and voltage
-  Parameter key
Scroll through parameters
-  Enter key
Save changes



Mode Indicator LEDs



















-  SOFT - Soft Start
-  MAN - Manual/Open loop
-  AUTO - Auto/Closed loop
-  STBY - Standby Mode
-  BST - Boost Mode



Figure 1

GITC-15 Quick Reference

- Global power on/off - press   
- Global setpoint - set desired setpoint, then press   
- Global mode - press   
- Global parameters -   



Set-Point Value Display



-  When decimal is lit, manual percentage power is engaged
-  When decimal is lit, output power is on
-  When decimal is lit, voltage is displayed $\pm 3\%$

Process Value Display



-  When decimal is lit, K type T/C is selected
-  When decimal is lit, amperage is displayed
-  When decimal is lit, temp. is displayed in Celsius

User Input Keypad

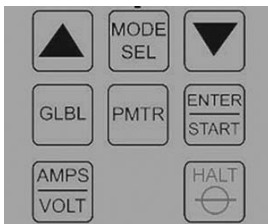



-  Global key
See *Global Functions* (Pg. 4)
-  Enter/Start key
Save changes or press once to exit Halt, or twice to start
-  Halt key
Halts the controller (inhibits output)



Figure 2

Basic Operation Procedures

The SITC-15 and GITC-15 temperature controllers are ready to run from factory settings.

Global Functions for GITC only:

GLOBAL FUNCTIONS allow individual controller parameters or modes to be sent to the system or groups of controllers. Group setup is configurable in parameter (**GITC P01**). Up to 4 groups can be set.

GLOBAL POWER ON/OFF: power on or off all controllers from any controller.

Key sequence: *GLBL*, *POWER*, then *ENTER/START*

Note*: If a controller is manually powered off, the function is disabled until powered back on manually.

GLOBAL SETPOINT/PARAMETERS: Adjust setpoint or parameters on a single unit, and send the settings to all controllers.

Key sequence: *GLBL*, *PMTR*, then *ENTER/START*

GLOBAL MODE CHANGE: Change the mode on a single unit, then change mode system wide or within a group. (e.g. STANDBY or BOOST)

Key sequence: *GLBL*, *MODE*, then *ENTER/START*

GLOBAL CURRENT/VOLTAGE VIEW: View current and voltage on all controllers in the system.

Key sequence: *GLBL*, *AMPS/VOLT*, then *ENTER/START*

Note*: If changes need to be made to individual controllers, just apply changes and press *ENTER*.

Basic Operation:

Turn power on by pressing the *POWER* button.

SOFT START mode: The controller will start in SOFT START mode if the process value is below 212° F or 100° C. After the SOFT START duration time (parameter (SITC - P16); (GITC - P20), the controller will go into AUTO mode (factory default).

Note*: MODE changes cannot be made during SOFT START mode unless the lock is disabled in parameter (SITC - P17); (GITC - P21).

SETPOINT CHANGE: To change the setpoint value, use the *UP* and *DOWN* keys to select the desired temperature then press *ENTER*. The minimum and maximum values for temperature and setpoint are 32° - 999° Fahrenheit (5° - 650° Celsius).

Mode:

There are 4 running modes available: manual (open loop), automatic (closed loop), standby (idle), and boost. A solid lit LED indicates the mode the controller is in.

To change mode:

Press the *MODE SELECT* key until the blinking LED is over the desired mode, then press the *ENTER* key. A solid lit LED will indicate the current running mode.

Note*: To exit the mode function with no changes, press the *MODE SELECT* then the *UP* or *DOWN* key.

Siren will momentarily sound when status changes occur (GITC only) (e.g. when BOOST is enabled).

ENTER must be pressed after any adjustment (such as setpoint, parameter, or mode) is made to store new information.

Standby and Boost:

The controller has two configurations for standby and boost modes: auto or manual.

Standby:

AUTO-STANDBY - controller goes to the preset standby set-point temperature set in parameter (SITC - P15); (GITC - P19).

MANUAL-STANDBY - controller goes to the preset % power set in parameter (SITC - P14); (GITC - P18).

The controller will remain in STANDBY mode until it is manually changed to another mode, or by pressing *MODE SELECT* then *UP* or *DOWN*.

Boost:

AUTO-BOOST - controller goes to the preset BOOST set-point temperature set in parameter (SITC - P12); (GITC - P16).

MANUAL-BOOST - controller goes to the preset % power set in parameter (SITC - P13); (GITC - P17).

Controller will remain in BOOST mode until preset time has elapsed, set in parameter (SITC - P11); (GITC - P15).

Parameter Changes:

1. Press the *PMTR* key until the desired parameter is reached. (List of parameters is available on (SITC - Pg. 7) (GITC - Pg. 8).
2. Press the *UP* or *DOWN* key to change the options for the selected parameter.
3. When complete, press the *ENTER* key to store to memory. (Changes can be made to all parameters before pressing *ENTER*).

To exit at any time, press the *ENTER* key.

Error Reset:

Upon detection of TOH, TSH, or HIA, the controller must be powered off, then on, to clear the error once the issue has been corrected. Refer to Pg. 9 for error codes.

Special Functions (GITC ONLY):

Even Temperature Rise: controllers will follow the slowest rising temperature in the system. Even temperature rise is an active procedure, so fluctuation will occur during rise.

Thermocouple Slaving at Startup: At startup, in the event of a thermocouple break, the controller will slave from a controller in the same group.

Live-Swap: In the event of a controller change-out, the new controller will automatically inherit the parameters and settings of the previous controller.

External Alarm Output: Relay for external alarm or light. Pinout on page: 14

Remote Standby Input: Switch input for system standby. Pinout on page: 14

SITC Parameters

#	Parameters	Defaults
P01	Auto Power On - (YES or NO)	YES
P02	Control Type - Power Control Type Phase or Burst mode (PH or BT)	PH
P03	Over Current Limit - (1 - 21) Amps	16
P04	Celsius or Fahrenheit (°C or °F)	F
P05	Thermocouple Type - (J or K)	J
P06	Over-temp. Alarm Limit - (8° - 30° Fahrenheit), (6° - 17° Celsius)	30
P07	Under-temp. Alarm Limit - (5° - 30° Fahrenheit), (5° - 17° Celsius)	30
P08	T/C Pinched - (1 - 250) seconds or (000 = disabled)	60
P09	Open TRIAC, Heater - (1 - 240) seconds or (000 = disabled)	30
P10	APO Enable - (YES or NO)	YES
P11	Boost Time Setting - (5 - 999) seconds	30
P12	Boost Temperature - (5° - 250° Fahrenheit), (5° - 120° Celsius)	75
P13	Manual Boost Power - (5 - 100%)	25%
P14	Manual Standby Power - (5 - 100%)	10%
P15	Standby Temperature - (50° - 350° Fahrenheit), (50° - 175° Celsius)	250
P16	Soft Start Time - (0 - 20) minutes	5
P17	Soft Start Lock - (YES or NO)	YES
P18	Audible Alarm - (YES or NO)	YES
P19	Keypad Lock - (YES or NO)	NO
P20	Frequency (Hertz) DISPLAY ONLY	
P21	Tune Stabilization - (50 - 100)	60

GITC Parameters

#	Parameters	Defaults
P01	Group - (1 - 4)	1
P02	Global Key Function Enable - (YES or NO)	YES
P03	Even Temperature Rise - (YES or NO)	YES
P04	Thermocouple Slaving - (YES or NO)	YES
P05	Auto Power On - (YES or NO)	YES
P06	Control Type - Power Control Type Phase or Burst mode (PH or BT)	PH
P07	Over Current Limit - (1 - 21) Amps	16
P08	Celsius or Fahrenheit (°C or °F)	F
P09	Thermocouple Type - (J or K)	J
P10	Over-temp. Alarm Limit - (8° - 30° Fahrenheit), (6° - 17° Celsius)	30
P11	Under-temp. Alarm Limit - (5° - 30° Fahrenheit), (5° - 17° Celsius)	30
P12	T/C Pinched - (1 - 250) seconds or (000 = disabled)	60
P13	Open TRIAC, Heater - (1 - 240) seconds or (000 = disabled)	30
P14	APO Enable - (YES or NO)	YES
P15	Boost Time Setting - (5 - 999) seconds	30
P16	Boost Temp. - (5° - 250° Fahrenheit), (5° - 120° Celsius)	75
P17	Manual Boost Power - (5 - 100%)	25
P18	Manual Standby Power - (5 - 100%)	10
P19	Standby Temp. - (50° - 350° Fahrenheit), (50° - 175° Celsius)	250
P20	Soft Start Time - (0 - 20) minutes	5
P21	Soft Start Lock - (YES or NO)	YES
P22	Audible Alarm - (YES or NO)	YES
P23	Siren Enable LOCAL (per module) - (YES or NO)	YES
P24	Siren Enable GLOBAL - (YES or NO)	YES
P25	Frequency (Hertz) DISPLAY ONLY	
P26	Address - DISPLAY ONLY	
P27	Tune Stabilization - (50 - 100)	60
P28	Keypad Lock - (YES or NO)	NO

Display Codes

Display Codes: Displayed on PRT (process temperature display)

Display Code	Description	Explanation
Hi	High Temperature	Process temp. over setpoint value.
Lo	Low Temperature	Process temp. under setpoint value.
OTC	Open Thermocouple	Thermocouple is open or break.
RTC	Reverse Thermo- couple	Thermocouple wire reversed.
PTC	Pinched Thermo- couple	Thermocouple has been shorted/ pinched.
TOH	Open TRIAC/Heater	TRIAC, heater is open.
TSH	TRIAC/Heater Shorted	TRIAC or heater shorted. (100% power output)
HIA	Over Current Detec- tion	Load has exceeded the amperage set in parameters.
APO	Average Power Output	Thermocouple is open and APO is currently running.
GLO	Global Function	Global key has been pressed. (GITC only)

NOTE: Power off controller before removing or inserting into mainframe

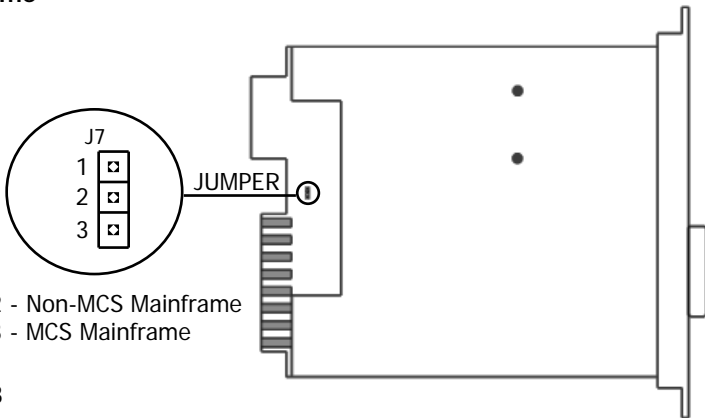

Pin 1 & 2 - Non-MCS Mainframe
Pin 2 & 3 - MCS Mainframe

Figure 3

Anti-Arcing Protection: Jumper J7 is to prevent damage to the contact points of the controller when removed from the mainframe while power is still on. J7 is set to pins 2 & 3 by factory default. If the controller is placed in a non-MCS mainframe, place jumper on pins 1 & 2. If jumper is placed incorrectly, a TOH error may occur (NO POWER OUPUT).

Mainframe Installation

INSTALLATION AND SERVICE SHOULD BE PERFORMED BY QUALIFIED PERSONNEL ONLY!

LOCATION:

The proper location is important for dependable service. The control systems should be located so as to allow free air movement into and out of the mainframe. Consideration should be given to allow the least exposure to heat, dust/dirt, moisture, and corrosive vapors. The front of the system must be readily accessible for set up and adjustment purposes.

It is recommended that a service disconnect switch be installed. This will provide a convenient means to completely disconnect all power from the temperature control system.

CONNECTING INPUT POWER:

1. Remove the input power access panel, located on the right side of the mainframe by removing the 8 phillips head screws. (Fig 4a)
2. Select input cable size and configuration based on load requirements and local electrical codes. Feed the cable through the cable clamp of the panel. (Fig 4b)
4. Strip wires and insert into the terminal block and tighten screws securely. (Fig 4a)
5. Replace the access panel.
6. Take up excess slack in the cable and secure with the strain relief clamp.
7. Route the AC input cable to a branch circuit (service) disconnect switch and connect to the fused side of the switch. Be sure the ground lead is attached to a proper earth ground.
8. Insert appropriate fuses for the main service fuse box.

Mainframe Input Power Diagram

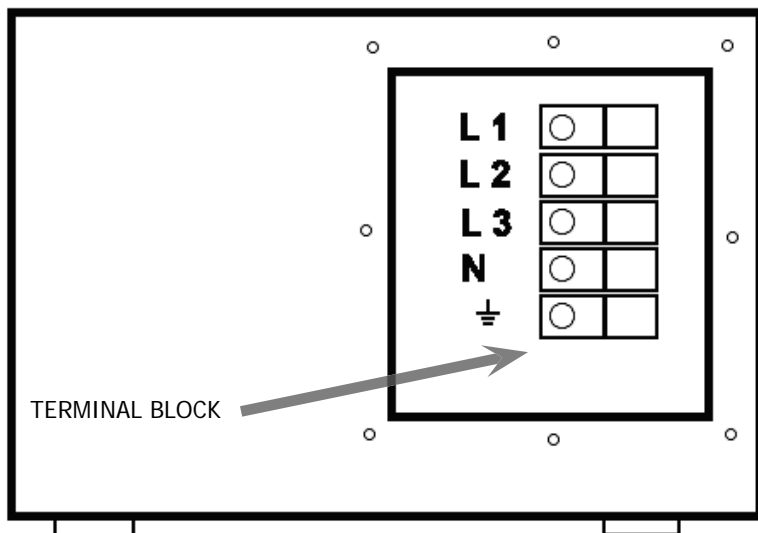

Figure 4a

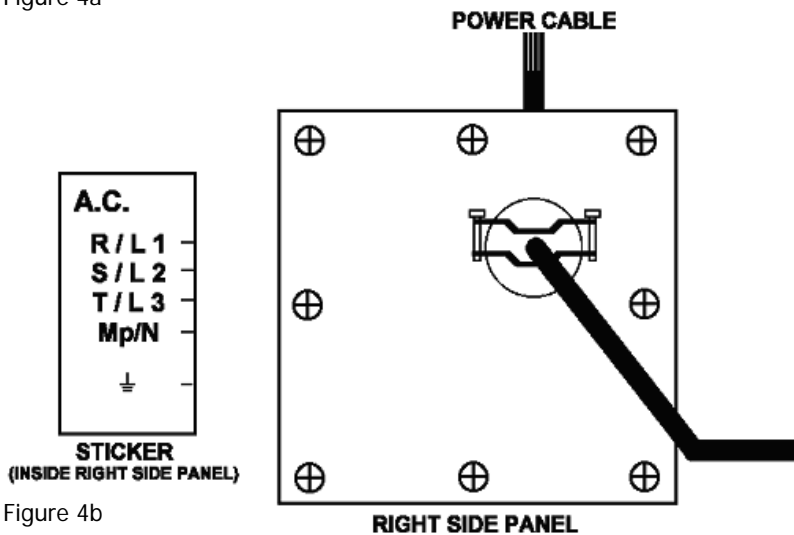

Figure 4b

Note:

Domestic: L1, L2, L3 + ground

Export: L1, L2, L3 + Neu + ground

Single Phase: L1 + Neu + ground

Mainframe Interconnection to Mold Terminal Box

Figure 5

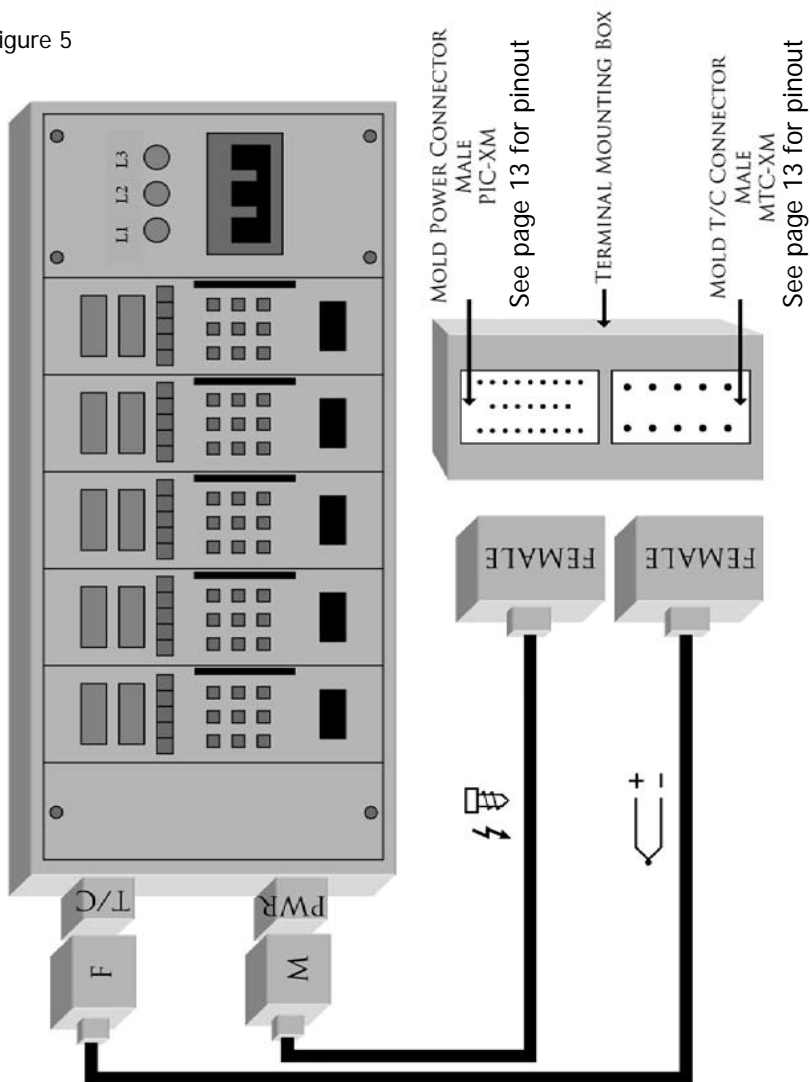
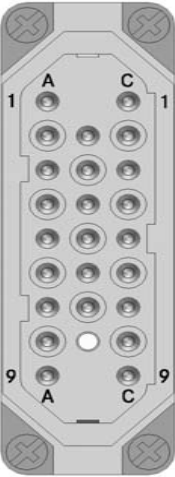

Figure 6a

Power Connector Pinout



Pin	Zone	Pin	Zone	Pin	Zone
A1	Zone 1			C1	Zone 8
A2		B2	Zone 5	C2	
A3	Zone 2	B3		C3	Zone 9
A4		B4	Zone 6	C4	
A5	Zone 3	B5		C5	Zone 10
A6		B6	Zone 7	C6	
A7	Zone 4	B7		C7	Zone 11
A8		B8		C8	
A9	Zone 12			C9	Zone 12

Figure 6b

T/C Connector Pinout

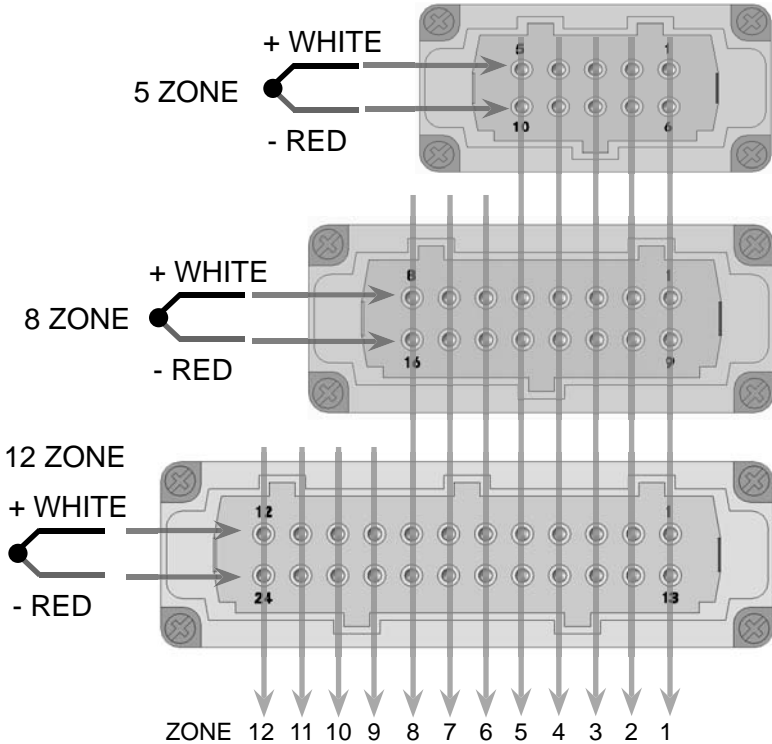

MFCP Mainframe (GITC ONLY)

MFCP mainframes come with communication and interface board with siren, which enables global functions, grouping, thermocouple slaving, even temperature rise, and Live Swap features. External alarm relay, and remote standby interface connector is located on the right side above the power input panel. Figures 7, a, and b below shows connector and external wiring circuits needed for these functions.

Alarm/Relay Output & Remote Standby Input Connector



Figure 7

Pin #	Function
1	Remote Standby Input
2	
3	Alarm/Relay Output
4	

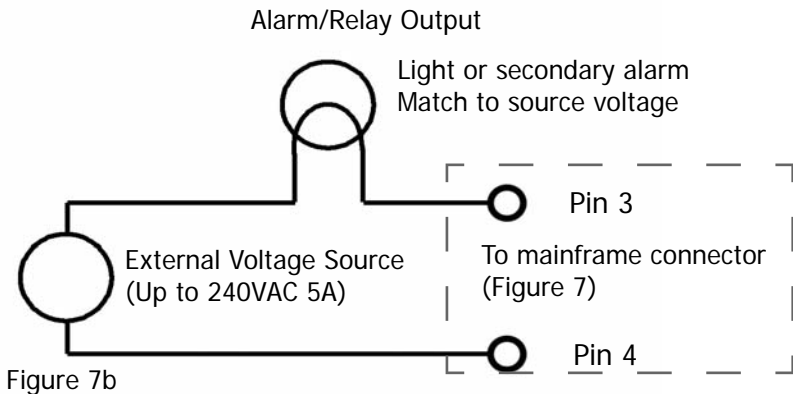
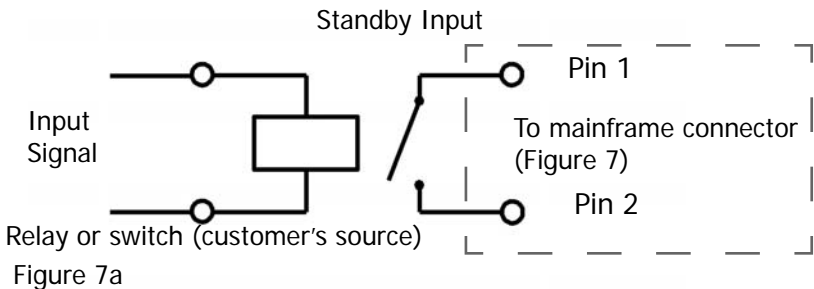

1 & 2 Zone Mainframe Power and Thermocouple Connector

Figure 8

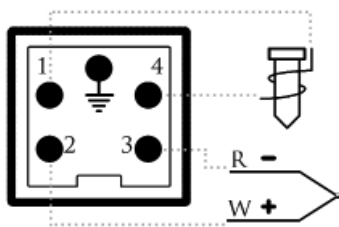

Pin #	Function
1	Power Output
2	T/C +
3	T/C -
4	Power Output
5	GND

3 Zone Mainframe Power and Thermocouple Connector

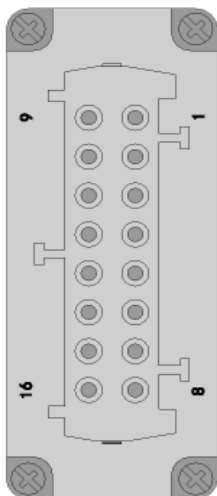

Figure 9

Pin #	Function	Pin#
1	Zone 1 Power Out	9
2	Zone 2 Power Out	10
3	Zone 3 Power Out	11
4	NC	12
5	NC	13
6	Zone 1 T/C Input	14
7	Zone 2 T/C Input	15
8	Zone 3 T/C Input	16

Note:

1, 2, and 3 zone mainframes are wired for single phase 240VAC operation.

Warranty

This product is guaranteed to be free from defects in materials and workmanship for a period of two years from the date of delivery. If the unit should malfunction, it must be returned to the factory for evaluation. Upon examination, if the unit is found to be defective, at our option, it will be repaired or replaced at no cost to the customer.

Warranty does not cover: contact points, fuses, or triacs.

Warranty is null and void when: Signs of abuse or tampering are found, incorrect fuse type is used, application of High Voltage rated over the system's required specifications, or application of High Voltage to thermocouple inputs.

MCS accepts no responsibility or liability for the APPLICATION by the customer of temperature controllers. This liability is assumed by the customer. Upon inspection, if the returned product does not meet our warranty requirements, customer may be subject to a reasonable service charge. There are no warranties, expressed or implied, for temperature controllers except as stated herein. In no event shall MCS be liable for consequential, incidental, or special damages beyond our control. The buyer's sole remedy for any breach of this agreement shall not exceed the purchase price paid by the buyer to MCS.

Mold Control Systems, Inc.
10501 S. Orange Ave. STE #108
Orlando, FL 32824

©2013 Mold Control Systems, Inc.
All rights reserved.